

MPA Cardboard Box Layer Palletizer

The layer palletizer system specifically for cardboard boxes and trays



Technical Specifications

Products		Cardboard boxes and trays
Conveying direction		lengthwise
Product width		145 - 300 mm
Product length		200 - 430 mm
Bundle height		50 - 300 mm
Bundle weight	max.	18 kg
Pallet format		800 x 1200 mm and 1000 x 1200 mm (40 x 48")
Pallet height	max.	1600 mm incl. pallet
Height empty pallet		130 mm (min.) – 150 mm (max.)
Weight full pallet	max.	1500 kg
Weight per layer	max.	280 kg
Lifting height of pallet hoisting device	min.	500 mm (recommended)
Bundle offset	max.	80 mm (possible with strapped or foil wrapped products; with loose products only to a certain limit)
Slip sheet (option)		Craft paper, air tight, 200 g/m ² , max. 1090 x 965 mm
Speed	max.	16 cycles/min.
Drive		Complete drive with 9 engines; total 5 kW 1/3 phase (with zero conductor ± 5%)
Voltage		400 V / NPE, 50 Hz
Fuse		3 x 20 A, slow-blow fuse
Air pressure	min.	6 bar
Air consumption	max.	0,35 Nm ³ /Min., unoiled, dry air
Palletizer programming		PLC with touch screen

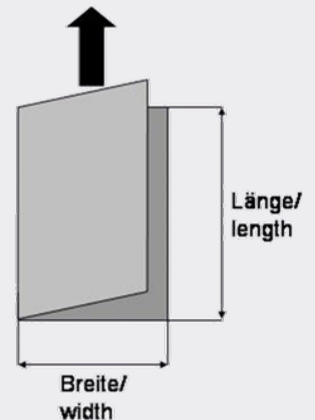

SEGBERT

PALLETIZING & AUTOMATION

Gutenbergstraße 16
D-48683 Ahaus

Telefon +49 (0) 25 61/95 04-0
Telefax +49 (0) 25 61/95 04-20
Mail segbert@segbert.com

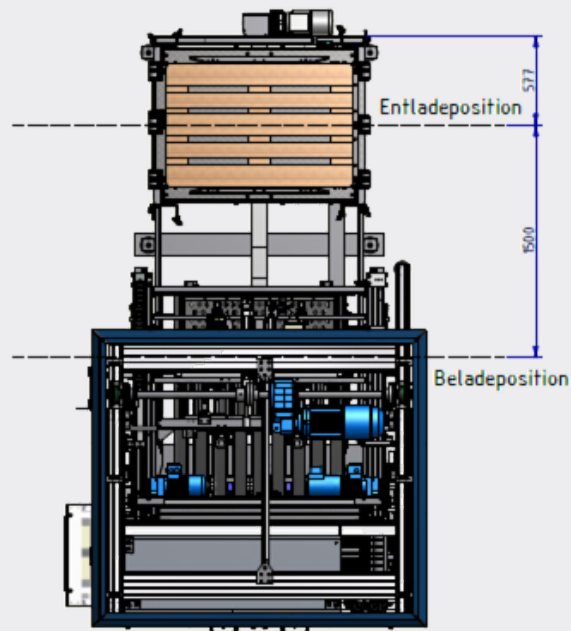
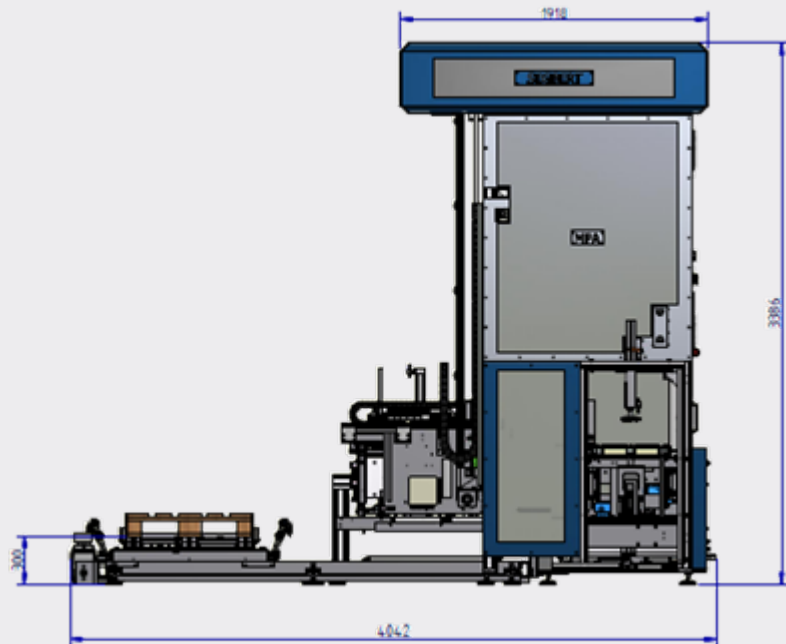

Volksbank Gronau Ahaus eG IBAN: DE33 4016 4024 0602 0192 00 BIC: GENODEM1GRN

Sitz der Gesellschaft: Ahaus Registergericht: Coesfeld, HRA 2848 UStID.: DE123788344 Steuernummer: 301/5750/0035
Komplementär: Segbert Verwaltungsgesellschaft mbH Sitz: Ahaus Registergericht: Coesfeld, HRB 4251
Geschäftsführer: Klaus Segbert

